

parkmate[®]

PTS411W

Parking Assist System

4 Sensor Wireless Parking Assist System



**User
Manual**



Contents

Important Notice	4
Disclaimer	4
About the Product	5
Key Features	5
Technical Specifications	6
Wireless Buzzer	6
Voice Adjustment	7
Learning Function	8
Self-Test Function	9
Attention	10
Sensor Maintenance	11
How Does The System Work	12
Box Contents	13
Installation Tools	13
Sensor Installation	14
Buzzer Installation	18
Function Test After Installation	19
Wiring Diagram	20
Troubleshooting	21
Warranty Terms & Conditions	22
Notes	26



Important Notice

1. This unit is for vehicles with 12/24V DC.
2. This unit should be installed by a professional auto-technician.
3. Always route wiring harnesses away from heat sources and electrical components.
4. Please check the position of sensors before you drill screw-holes.
5. Ensure you test the unit after installation.

Disclaimer



The PTS411W Parking Assist System has been designed to help drivers reverse and park, but is not a substitute for driver discretion. You should always pay close attention to your surroundings when you drive and use this system as an aid only.



Parkmate does not guarantee or assume liability for collisions or damages while the PTS411W is in use.

About the Product

The PTS411W Parking Assist System is a 4-senor parking system that can be used as a rear ultrasonic distance monitoring device. It electronically detects the area behind your vehicle while reversing.

If the sensors detect an obstacle, audible sound alerts will help assist you to safely manoeuvre or park your vehicle. With anti-interference and anti-false alert technology, the system works quickly and in most weather conditions. The system has intelligent detection, ideal for vehicles with a tow-bar or spare tire.

The system is reliable at a wide storage temperature range and is useful when parking in harsh weather conditions or at night. With the help of the PTS411W, you can enjoy a more comfortable, relaxed and safer parking experience.

Key Features

- 4 rear sensor system
- Easy installation
- Wireless from control unit to buzzer
- Volume adjustable
- Suitable for 12-24V vehicles
- Self-test function
- Truck sensor for commercial vehicles
- All weather design (-40°C - +85°C)

Technical Specifications

- Input voltage: 12/24V \pm 3V
- Detection range: 0.1m - 2.0m
- Alarm range/buzzer: 0.3m - 1.5m
- Buzzer SPL: 70 - 90dB
- Operating temperature: -40°C - +85°C

Wireless Buzzer

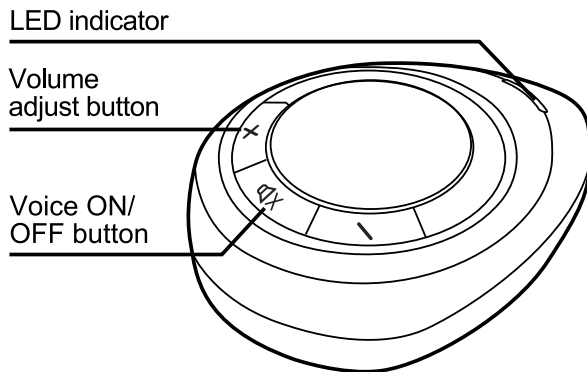

Voice Adjustment

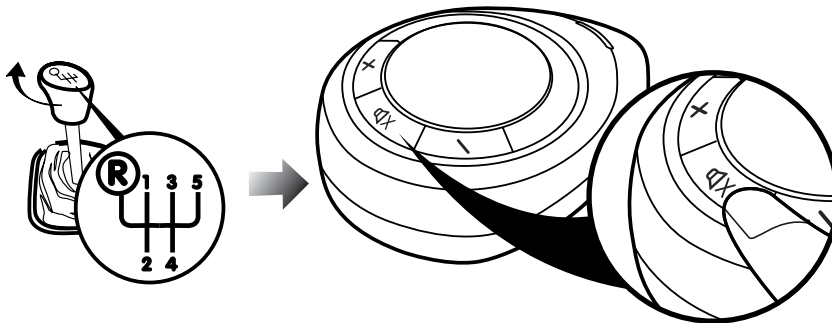

Once reverse gear is engaged, press and hold the  button for 2 seconds to turn the voice alarm ON/OFF.

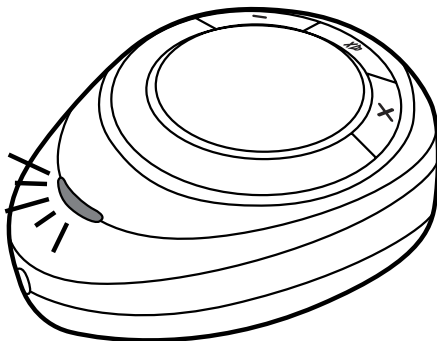

Red LED light flashes 3 times:
Voice alarm OFF.

Blue LED light flashes 3 times:
Voice alarm ON.

Voice Adjustment

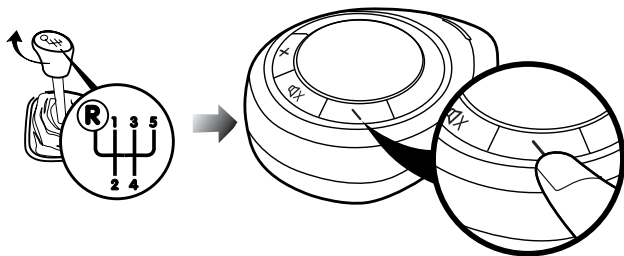

You can choose either high, medium or low volume.

Once reverse gear is engaged, press the “+/-” button to adjust the volume.

When the obstacle distance is less than 0.3m, an audible warning will sound.

Learning Function

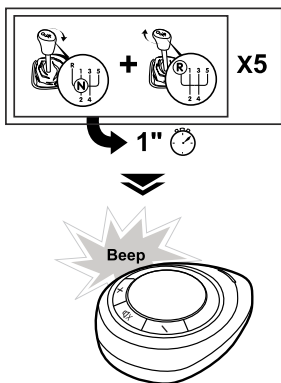

The system has intelligent detection, which is ideal for vehicles with a tow-bar or spare tire. By using the Learning Function, your vehicle will learn to ignore fixed items attached to your car that otherwise might confuse the sensor and lead to false alarms.

Please follow these directions to use this function:

1. With the ignition ON, change the gear from “N” to “R” 5 times (gear change must be within 1 second).
2. After 5 times, leave the gear in “R” position.
3. After 8 seconds the buzzer will beep twice to complete the learning process.

Re-setting the Learning Function

1. With the ignition ON, change the gear from “N” to “R” 8 times (gear change must be within 1 second).
2. After 8 times, leave the gear in “R” position.
3. After 8 seconds, the buzzer will beep once to indicate that the Learning Function has cleared successfully and the system has reset.

TIPS: Leave the vehicle in “R” position for 2 seconds to clear the system memory and start the above learning procedure again, if you need to start again.

Self-Test Function

To test your Parking Assist System, put your car into reverse. If all sensors are working normally, the buzzer will beep once.

If a damaged or defective sensor is detected, then the system will:

- Beep three times
- Other sensors will continue to work normally.

1. All sensors are working normally

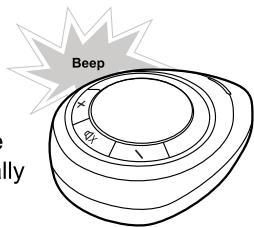

2. Damaged sensor is detected

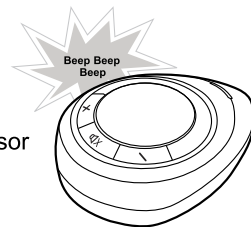

Attention

False-detection may occur in the following situations:

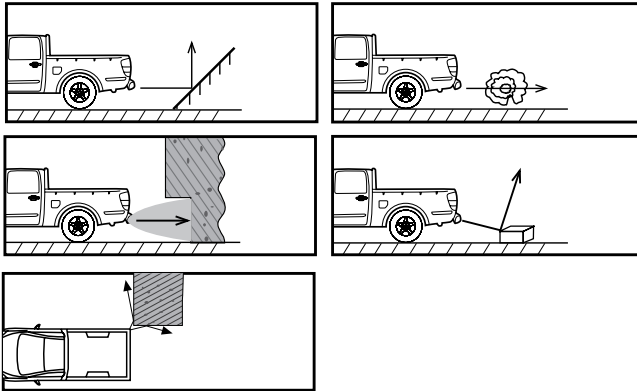

- Please fully-test the system after installation to ensure it works.
- Heavy rain, dirt or damaged sensors can cause false warning.
- Ensure that the self-test procedure is completed and all sensors are functioning before reversing.

Sensor Maintenance

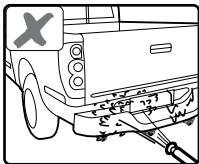

Do not wash the sensor with a high pressure washer.

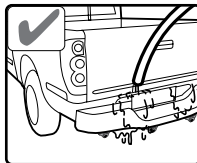

Please wash the car with a low pressure washer.

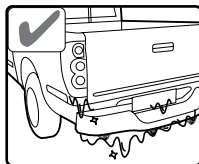

If the sensors are covered with ice, please use warm water to gently melt the ice away.

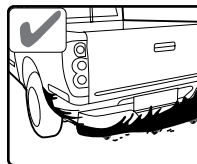

If covered in mud or snow, please wash your sensors with a cloth or low-pressure hose.

How Does The System Work

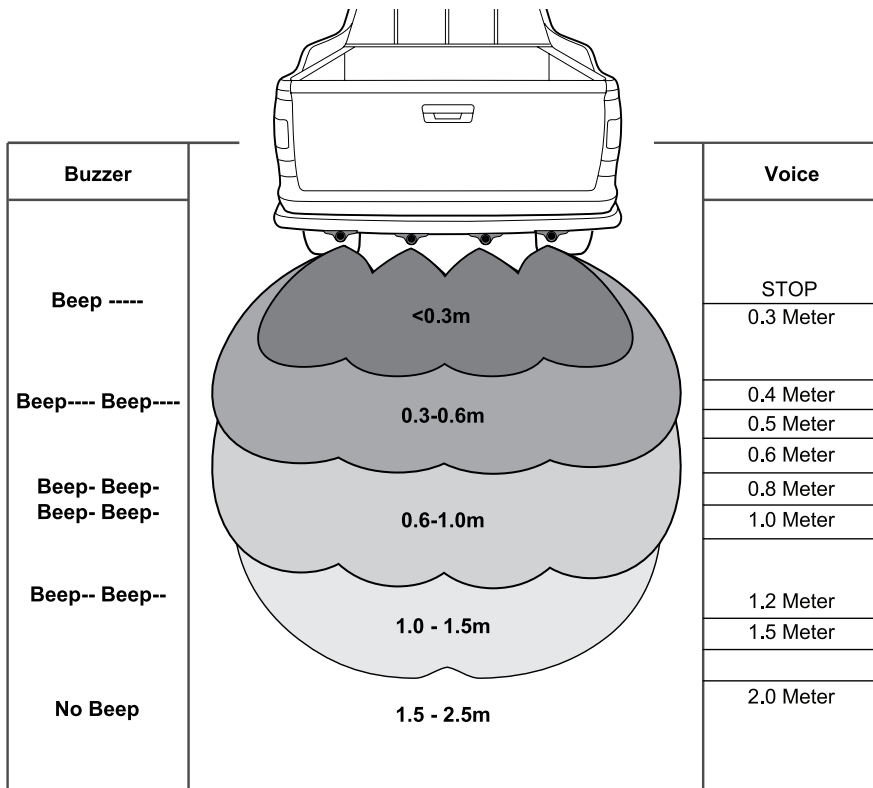

Box Contents

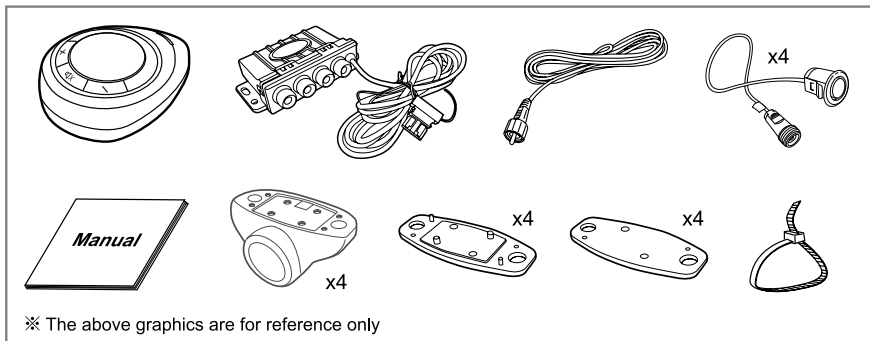

Installation Tools

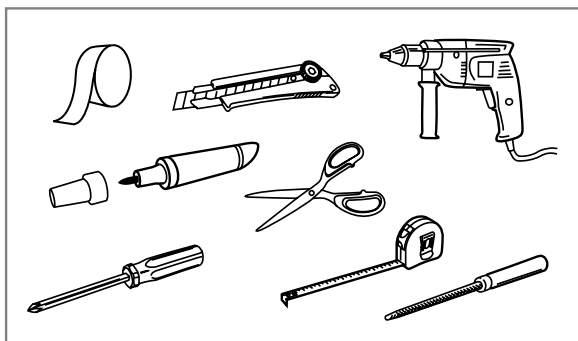

45' ~ 60'

Sensor Installation

Please adjust the sensor angle according to the sensor height and bumper angle to avoid detecting the ground.

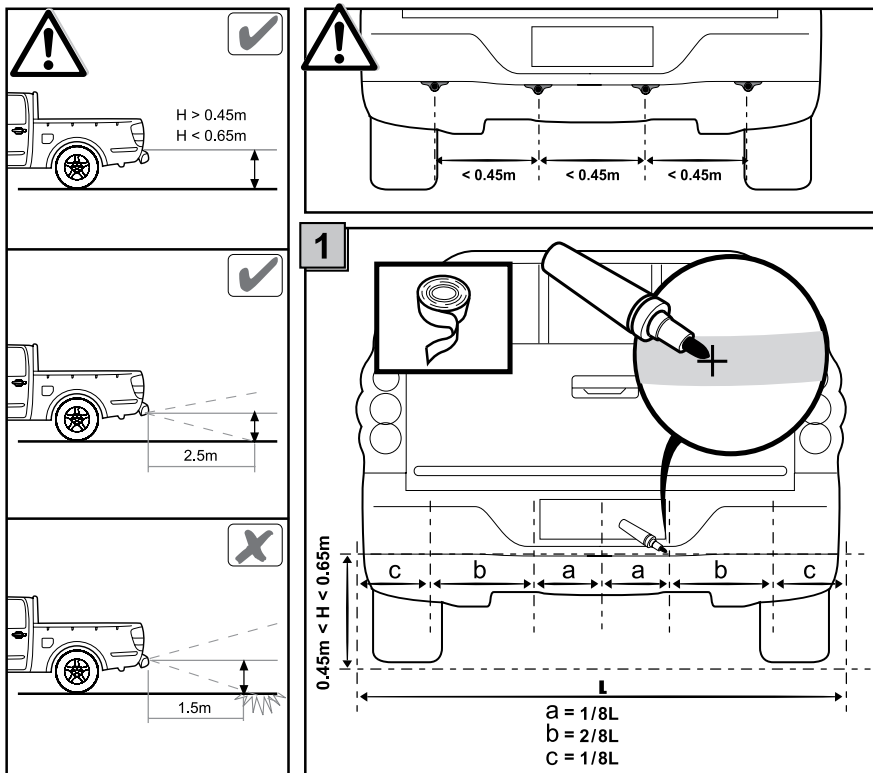

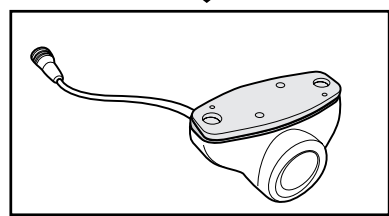
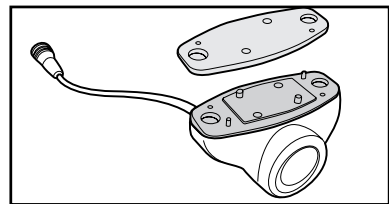
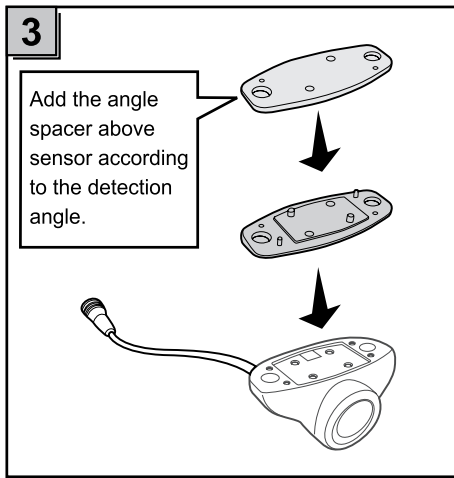
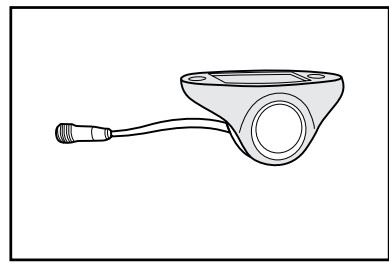
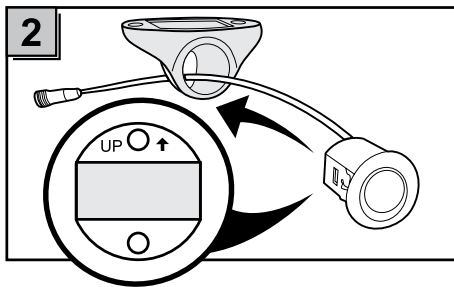

4

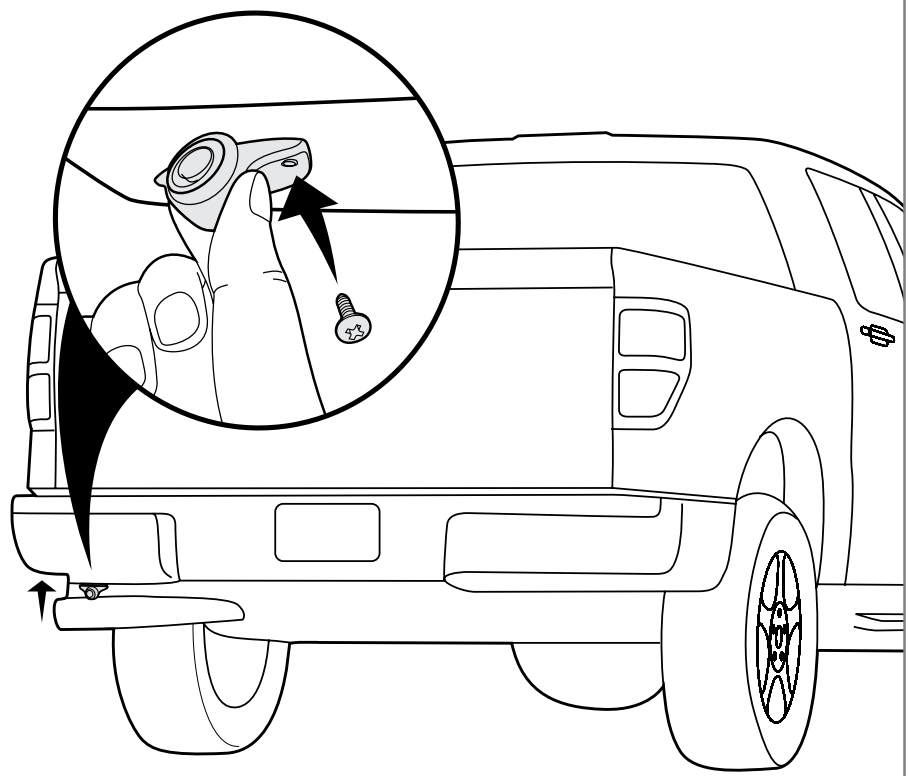

5

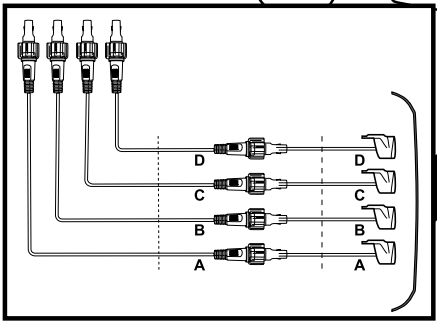
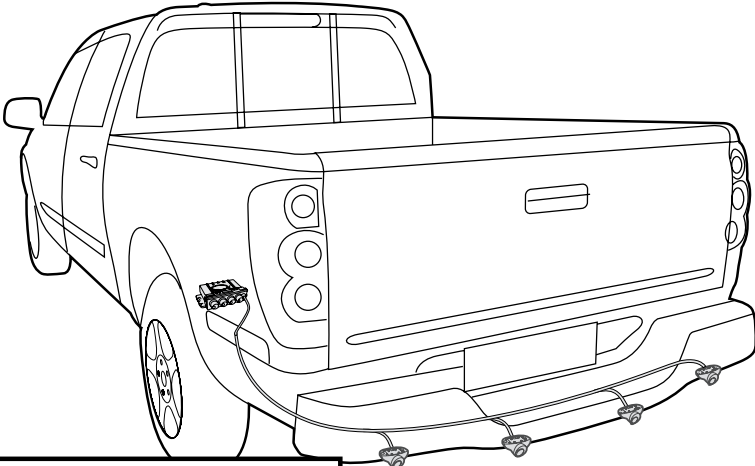

Buzzer Installation

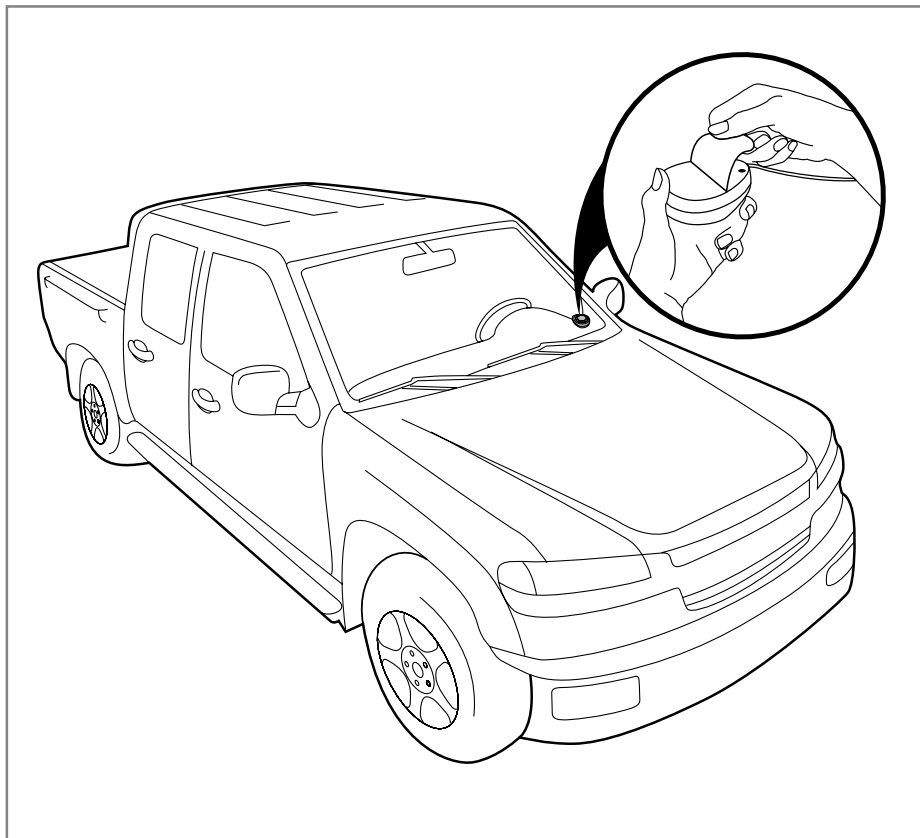

Function Test After Installation

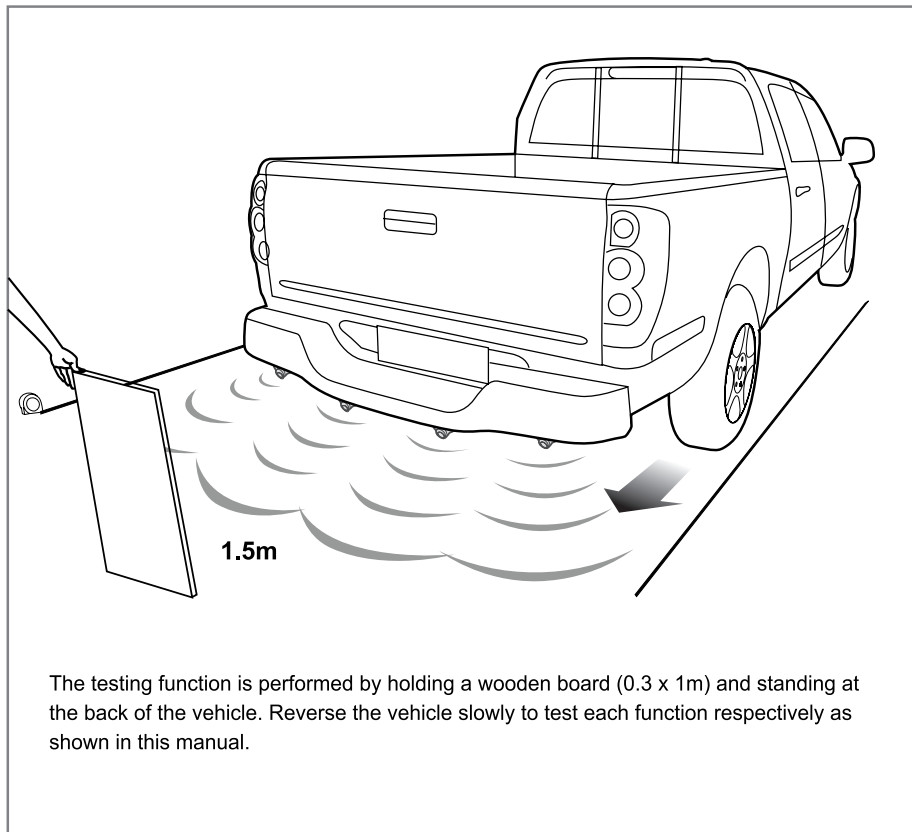

Wiring Diagram

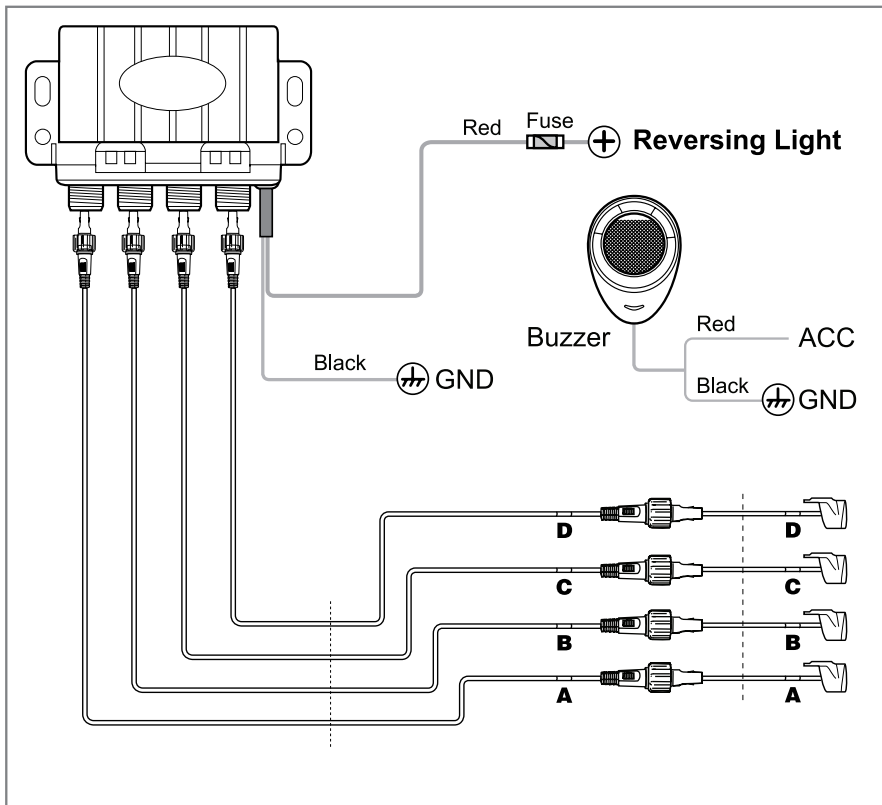

Troubleshooting

After installation, the buzzer does not work

- a) Are all wires connected properly?
- b) Is the vehicle's ignition ON?
- c) Is reverse gear engaged? (the reversing light should be turned on)

Damaged sensor detected

- a) Are all sensors plugged into the ECU correctly and tightly?
- b) Is the sensor faulty?
- c) Is the sensor covered by dirt or snow?
- d) Is the sensor damaged?

False warning

- a) Are all sensors plugged into the ECU correctly and tightly?
- b) Is the sensor detecting the ground?
- c) Has the rubber ring in the sensor come out? (14D sensor)

Warning sound is too low or too high

- a) Press the volume button to adjust the volume to a suitable level.

If the problem persists, please follow these steps:

- a) For consumers: contact your dealer or nearby service centre.
- b) For installers or dealers:
 - 1) Test the sensors with a certified ECU by using a flat wooden board.
 - 2) Replace the ECU and re-check the system.
 - 3) Plug the certified sensors into the ECU and re-check.
 - 4) Email your question to us and we will reply ASAP.

Warranty Terms & Conditions

Our goods come with guarantees that cannot be excluded under the Australian & New Zealand Consumer Law. You are entitled to a replacement or refund for a major failure and for compensation for any other reasonably foreseeable loss or damage. You are also entitled to have the goods repaired or replaced if the goods fail to be of acceptable quality and the failure does not amount to a major failure.

This warranty is provided in addition to your rights under the Australian & New Zealand Consumer Law.

Directed Electronics Australia Pty Ltd (Directed Electronics) warrants that this product is free from defects in material and workmanship for a period of 12 months from the date of purchase or for the period stated on the packaging. This warranty is only valid where you have used the product in accordance with any recommendations or instructions provided by Directed Electronics.

This warranty excludes defects resulting from alterations of the product, accident, misuse, abuse or neglect.

In order to claim the warranty, you must return the product to the retailer from which it was purchased or if that retailer is part of a National network, a store within that chain, along with satisfactory proof of purchase. The retailer will then return the goods to Directed Electronics. Directed Electronics will repair, replace or refurbish the product at its discretion. The retailer will contact you when the product is ready for collection. All costs involved in claiming this warranty, including the cost of the retailer sending the product to Directed Electronics, will be borne by you.

Directed Electronics Address:

115-119 Link Road Melbourne Airport, 3045 Victoria. Australia

Ph: +61 03 8331 4800

Email: service@Parkmate.com.au

To view the complete Parkmate range or for details on how to contact us, please visit our website at www.Parkmate.com.au | www.Parkmatehd.co.nz

INDEMNITY

You agree to defend, indemnify and hold harmless Parkmate and its subsidiaries and affiliates from and against any and all claims, proceedings, injuries, liabilities, losses, costs and expenses (including reasonable legal fees), including but not limited to, claims alleging negligence, invasion of privacy, copyright infringement and/or trademark infringement against Parkmate and its subsidiaries and affiliates or the Parkmate services, relating to or arising out of your breach of any provision of these terms, your misuse of the Parkmate or Parkmate services, or your unauthorized modification or alteration of products or software.

WARRANTY AND WARRANTY DISCLAIMER

Parkmate has a limited warranty whereby Parkmate warrants to and only to you that the Parkmate mirrors & monitors, sensors, cameras & accessories will be free from defects in materials and workmanship for one (1) year from the date of your purchase of the Parkmate mirrors & monitors, sensors, cameras & accessories (unless a longer warranty period is required by law). The specifics of this Parkmate limited warranty are at <https://www.Parkmate.com.au/warranty>

To the extent possible under governing law, other than the above product warranty for the Parkmate mirrors & monitors, sensors, cameras & accessories you understand and agree that the Parkmate services are provided on an “as is” and “as available” basis. Parkmate makes no warranty that the Parkmate services will meet your requirements or that use of the Parkmate services will be uninterrupted, timely, secure or error-free nor does Parkmate make any warranty as to the accuracy or reliability of any information obtained through the Parkmate services (including third party content), that any defects in the Parkmate services will be corrected or that the Parkmate products or Parkmate services will be compatible with any other specific hardware or service.

You agree that Parkmate is not an insurer and that Parkmate is not providing you with insurance of any type. Any amounts that you pay Parkmate for the Parkmate service are not insurance premiums and are not related to the value of your vehicle



or property, anyone else's property located in your vehicle or premises, or any risk of loss in your vehicle or at your premises. If you want insurance to protect against any risk of loss at your vehicle or premises, you will purchase it. In the event of any loss, damage or injury, you will not look to Parkmate to compensate you or anyone else. You release and waive for yourself and your insurer all subrogation and other rights to recover against Parkmate arising as a result of the payment of any claim for loss, damage or injury.

Parkmate's equipment and services do not cause and cannot eliminate occurrences of certain events, including, but not limited to, vehicle accidents, property damage, lost property, theft of vehicle, theft of property. Parkmate makes no guarantee or warranty, including any implied warranty of merchantability or fitness for a particular purpose, that the Parkmate equipment and services provided will detect or avert such incidents or their consequences. Parkmate does not undertake any risk that you or your vehicle or property, or the person or property of others, may be subject to injury or loss if such an event occurs. The allocation of such risk remains with you, not Parkmate.



Other than the above product warranty for the Parkmate mirrors & monitors, sensors, cameras & accessories Parkmate and its suppliers disclaim all warranties of any kind, whether express, implied, or statutory, regarding the Parkmate equipment and any associated app/service. Including any implied warranty of title, merchantability, fitness for a particular purpose, or non infringement of third party rights. Because some jurisdictions do not permit the exclusion of implied warranties, the last sentence of this section may not apply to you.

Parkmate hereby further expressly disclaims all liability for any claims for service failures that are due to normal product wear, product misuse, abuse, product modification, improper product selection or your non-compliance with any and all applicable federal, state or local laws. This warranty and warranty disclaimer give you specific legal rights, and you may have other rights that vary by state, province, or country. Other than as permitted by law, Parkmate does not exclude, limit or suspend other rights you have, including those that may arise from the



nonconformity of a sales contract. For a full understanding of your rights you should consult the laws of your state, province, or country. For our Australian customers: please note that this warranty is in addition to any statutory rights in Australia in relation to your goods which, pursuant to the Australian consumer law, cannot be excluded.

Limitations of Parkmate liability

Under no circumstances will Parkmate be liable in any way for any content, including, but not limited to, the loss of content, any errors or omissions in any content, or any loss or damage of any kind incurred in connection with use of or exposure to any content posted, emailed, accessed, transmitted, or otherwise made available via the Parkmate app.

Parkmate liability for damages, especially for breach of duty or obligation, delay in performance, non-performance, or malperformance shall be precluded, except when these are due to negligent breaches of any significant contractual duty or obligation on the part of Parkmate. Any liability for negligence is limited to direct losses usually and typically foreseeable in such case. Should the claim for damages be based on willful or grossly negligent breach of contractual duty or obligation on the part of Parkmate, the preclusion and limitation of liability mentioned in the preceding sentences will not apply. The preceding preclusion and limitation of liability will also not apply to claims for damages arising out of loss of life, bodily injury or health impacts for which Parkmate may be liable, or for non-contractual liability.

Some states and countries do not allow the exclusion or limitation of incidental or consequential damages, so the above limitation or exclusion may not apply to you. Additionally, this provision is not intended to limit Parkmate's liability in the event of Parkmate's willful or intentional misconduct.

NOTES



parkmate[®]



All Images, Information and Content are Copyright © 2021
Directed Electronics Australia Pty Ltd. All Rights Reserved.

www.parkmate.com.au | www.parkmatehd.co.nz

DIRECTED
AUSTRALIA & NZ

www.directed.com.au
www.directed.co.nz